

# Logistic Track

**New Haven's** logistic track can be used in many applications: moving and storage, commercial, industrial, and handicapped transportation. Designed for use with all models of **New Haven's** spring loaded "E" end fittings.

### Series E Track Horizontal

Material: 12 Gauge high strength steel  
Weight: 16.6 lbs.  
Length: 10'  
Finish: Iron phosphate primer green or Galvanized\*



Series E Track Horizontal  
(iron phosphate primer green)

		QTY	1-19	20-49	50-99	100+
NH43002	Painted		25.90	25.20	24.80	24.15
NH718-01-120	Galvanized*		28.25	27.55	27.10	26.50

### Series E Track Mounting Plate

Countersunk mounting holes. Overall size: 4-3/8" x 3-3/4"



2 position  
E Track  
Mounting  
Plate

		QTY	1-19	20-49	50-99	100+
NH720TP2	2 position		8.10	7.90	7.70	7.40

### Series E Track Mounting Plate

Countersunk mounting holes. Overall size: 7/18" x 4-1/2"



4 position  
E Track  
Mounting  
Plate

		QTY	1-19	20-49	50-99	100+
NH720TP4	4 position		10.50	10.10	9.75	9.40

### Heavy-Duty Series A Track Horizontal

30 mph/20G Wheelchair crash tested  
Material: 11 Gauge high strength steel  
Weight: 21.1 lbs.  
Length: 10'  
Color: Iron phosphate primer green



Heavy-Duty Series A Track  
Horizontal

		QTY	1-19	20-49	50-99	100+
NH702H-01-120	Painted		32.55	31.70	31.10	30.55

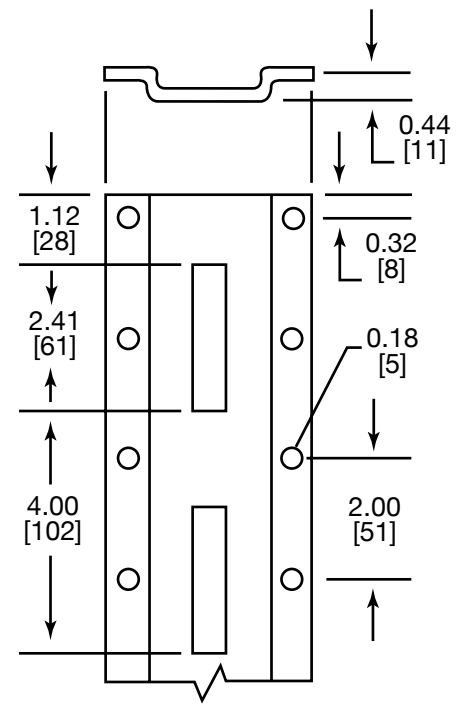

Heavy-Duty Series A Track Vertical  
(iron phosphate primer green)

### Heavy-Duty Series A Track Vertical

Material: 11 Gauge high strength steel  
Weight: 13.9 lbs.  
Length: 10'  
Finish: Iron phosphate primer green or Galvanized\*

		QTY	1-19	20-49	50-99	100+
NH720V-01-120	Painted		36.50	35.65	35.05	34.25
NH728V-01-120	Galvanized*		36.50	35.65	35.05	34.25

Series F Track  
Horizontal or  
Vertical

### Series F Track Horizontal or Vertical

Material: 15 Gauge high strength steel  
Weight: 6.2 lbs.  
Length: 10'  
Finish: Galvanized\*

		QTY	1-19	20-49	50-99	100+
NH43003	Galvanized*		20.00	19.80	18.90	18.50

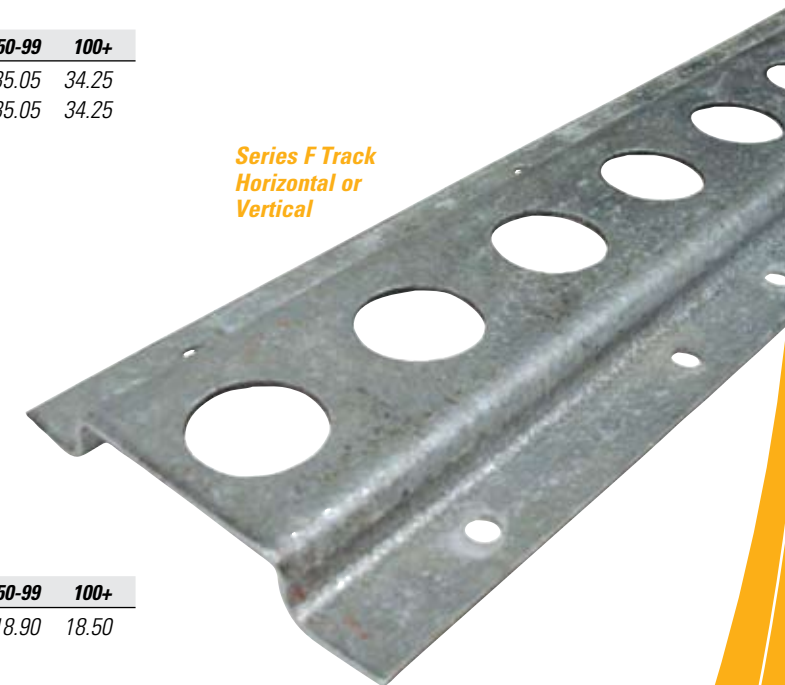

\* Caution: Toxic fumes may result when welding galvanized material. Use proper ventilation.

An assembly is rated at the lowest minimum working load limit of any of its components. Component selections will affect overall ratings of the assembly.

\* Caution: Toxic fumes may result when welding galvanized material. Use proper ventilation.

An assembly is rated at the lowest minimum working load limit of any of its components. Component selections will affect overall ratings of the assembly.